

B M R FCR06, FCR12

Power factor correction controller

User and service manual



version 3.1

Content

1. Control and signal elements.....	3
2. Device description.....	4
3. Instruction manual for connection and operation.....	5
4. Description of the function.....	5
5. Installation of the device.....	6
6. Regulator parameter setting.....	8
6.1. Target cosF setting (CoS1, CoS2).....	10
6.2. Setting of current or voltage transformer ratio (I_{tr} , U_{tr}).....	10
6.3. Automatic detection of compensation stages (Auto).....	10
6.4. Deceleration of regulation at over compensation (SHtd).....	10
6.5. Manual setting of compensation stages (St_P).....	11
6.6. Discharging time (dItI).....	11
6.7. Delay for disconnection (dIPA).....	11
6.8. Number of stage circuit closing (rSSt).....	11
6.9. Fixed capacitor stages (FISt).....	11
6.10. Connection configuration (CoCo).....	11
6.11. Reactive power offset (rCPo).....	12
6.12. Regulation to average or instantaneous power factor ($\bar{\text{CoS}}$).....	12
6.13. Averaging time for APFR (tACo).....	13
6.14. Recording of number of operations and maximum values (C_St).....	13
6.15. De-compensation steps settings (E_IC).....	13
6.16. Alarms.....	13
6.17. Configuration of RS485 communication port.....	14
6.18. Parallel work of two controllers (CASC).....	14
6.19. Password for entering configuration mode (CodE).....	14
6.20. Restart (rES).....	14
7. Displayed values.....	15
7.1. Maximums.....	15
7.2. Cos ϕ	16
7.3. Apparent current.....	16
7.4. Voltage.....	16
7.5. Powers.....	16
7.6. De-compensation delay.....	16
7.7. Number of stage circuit closings.....	16
7.8. System frequency.....	16
7.9. Temperature.....	16
8. Manual operation.....	17
9. Alarm notification.....	17
10. Technical features.....	18

1. Control and signal elements

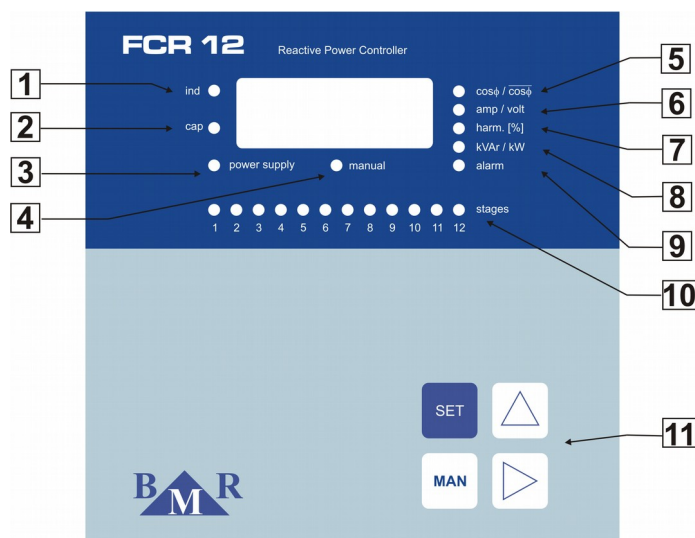

Picture 1. Description of front control panel

- 1. **LED ind** – it is ON in the case of inductive $\cos\phi$
- 2. **LED cap** – it is ON in the case of capacitive $\cos\phi$
- 3. **LED power supply** – it is ON when there is power supply to electrical network
- 4. **LED manual** – it is ON at manual operation of capacitor stages
- 5. **LED $\cos\phi$** – it is ON when instantaneous or average value of $\cos\phi$ is shown on the display
- 6. **LED amp/volt** – it is ON when value of measured current / voltage is shown on the display
- 7. **LED harm.** – it is ON when total harmonic distortion of current / voltage is shown on the display
- 8. **LED kvar/kW** – it is ON when powers are shown on the display
- 9. **LED alarm** – it is ON when alarm is present
- 10. **LED STAGES** – dichromatic LEDs indicate status of each stage individually
- 11. Buttons for regulator control

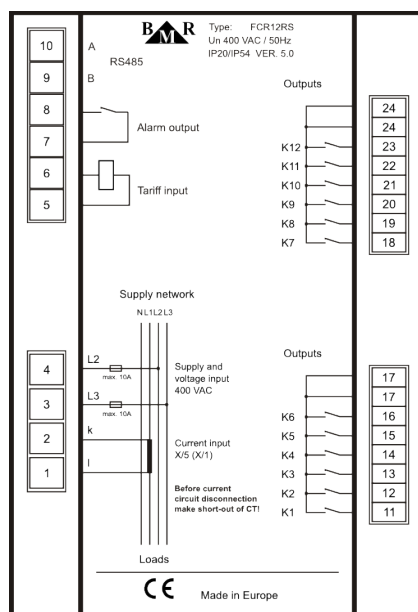

Picture 2. Device terminal connection

2. Device description

Power factor correction regulator FCR06 and FCR12 are designed for power factor control in low and medium voltage system networks 50/60 Hz. FCR06 and FCR12 regulator belong to the group of fast regulators and allow to make regulation up to 25 times per second. This feature allows to FCR regulator to control mechanical contactors and also fast semiconductor stages.

FCR06 and FCR12 regulators measure and display also following parameters:

Parameter	Display	Maximum
Instantaneous $\cos\phi$, average $\cos\phi$ (capacitive, inductive)	•	
Line voltage between measured phases	•	•
Current in the measured phase	•	•
System frequency	•	•
Apparent three-phase power	•	•
Active three-phase power	•	•
Reactive three-phase power	•	•
Allowed reactive power	•	•
Odd current harmonics (1 ... 19) in %	•	•
Total harmonic distortion of current THDI	•	•
Odd voltage harmonics (1 ... 19) in %	•	•
Total harmonic distortion of voltage THDU	•	•
Number of connections of each stage	•	
Total time of step usage of each step	•	
Temperature	•	

Table 1. Measured and displayed parameters

Regulator is available with 6 and 12 stages design. Regulator FCR06 has available 1 x 6 outputs and regulator FCR12 has available 2 x 6 outputs. Outputs for mechanical contactors are with relays and outputs for semiconductor contactors are realized by OPTO-MOSFET transistors, which are able to operate under 24 V DC / 100 mA or 230 V AC / 100 mA (maximum) according to regulator variant.

Regulator variant	Total number of all stages	Number of dynamic stages	Control voltage
FCR 06	6	0	230 VAC
FCR 06-01	6	1	230 VAC
FCR 06-02	6	2	230 VAC
FCR 06-03	6	3	230 VAC
FCR 06-06	6	6	24 VDC or 230 VAC
FCR 12	12	0	230 VAC
FCR 12-01	12	1	230 VAC
FCR 12-02	12	2	230 VAC
FCR 12-03	12	3	230 VAC
FCR 12-06	12	6	24 VDC or 230 VAC
FCR 12-12	12	12	24 VDC or 230 VAC

Table 2. Controller variants for contactor and semiconductor stages

Regulators FCR06 and FCR12 are available in several variants of supplying and measuring voltage. In case that auxiliary power supply is used (measuring voltage is different than supply voltage) the alarm output is not available.

Regulator variant	Power supply voltage	Measuring voltage	Alarm output
FCR 06	400 VAC	400 VAC	yes
FCR 12	400 VAC	400 VAC	yes
FCR 06 V100	100 VAC	100 VAC	yes
FCR 06 V230	230 VAC	100 ... 690 VAC	no
FCR 12 V100	100 VAC	100 VAC	yes
FCR 12 V230	230 VAC	100 ... 690 VAC	no

Table 3. Controller variants according to power supply and measuring voltage

3. Instruction manual for connection and operation

Default parameters are set to the device in production, according to the table 4. Supply voltage has to be taken from regulated network, because it is used also for voltage measuring circuit. Value of this supply voltage is on the product label. Current for current measuring circuit is taken from the remaining phase. By default, in the case of 3 x 400 V, voltage is being measured between phases L2 and L3, and the current is being measured in the phase L1. The connection of measuring circuits is shown at picture 3.

Commissioning procedure:

1. Make connection according to connection diagram at picture 5.
2. Connect supply voltage. In the case that the value of current is lower than 3 mA, the display will show "----". If not, the display will show instantaneous value of power factor.
3. Press button **SET** for the time longer than 5 seconds. After that device will switch to the configuration menu and on the display will appear parameter **CoS1**.
4. By pressing the button **SET** once again display will show target $\cos\phi$. Setting the targeting values of $\cos\phi$ is done via buttons **▲** (+) and **▶** (-) .
5. Confirmation of the set value **CoS1** is done by pressing the button **SET**.
6. Press the button **▲** until the parameter **Itr** will appear on the display. It means ratio of current transformer.
7. Press the button **SET** and on the display will appear set value of transformer ratio (default value is 1).
8. Using the buttons **▲**, **▶** set known value of transformer ratio.
9. By pressing button **SET** confirm set value. On the display will appear again the parameter **Itr**.
10. In the case that measuring / supplying voltage is taken from voltage transformer, move to the parameter **U_tr** by pressing button **▲**. For example, if the ratio is 22000 / 100, then it should be set like 220.
11. Now again, by using the buttons **▲**, **▶** move to the parameter **Auto** and by pressing button **SET** confirm it. Via button **▲** switch to the value **on** and via button **SET** confirm set value. Device automatically perform phasing of measured voltage, current and detection of connected compensation stages. All parameters will be saved to the internal memory. When the detection is finished, parameter **Auto** will be automatically changed to the value **off**.
12. Verify if detection of power of all stages was done correctly. Press button **SET** for time of 5 seconds. On display will appear **CoS1**, via pressing button **▲** move to the parameter **St_P**. Press again button **SET** and **LED1** of first stage will be turned **on**. Another pressing the button **SET** will make the value of the power of the first stage be shown on the display. If the value is not correct, it should be changed by pressing buttons **▲**, **▶** until the correct value. In the case of capacitor stage **LED cap**, placed at the left side of display, has to light. If the power is correct press again button **SET** and on the display will appear again parameter **St_P**. Via button **▲** move to another stage and **LED2** will turn ON. Repeat the same procedure the same way like for the first stage. Following the same control or setting of all stages should be done. At the end press button **SET** until value of power factor will appear on the display.
13. If everything is set correctly, on the display is shown real instantaneous value of power factor. Regulator FCR06 or FCR12 is ready for operation.

Other parameters may remain on having the default values, that were made by the manufacturer. In the case that further changes are necessary, the user should follow detailed manual given in chapter 6.

4. Description of the function

Device digitizes measured phase to phase voltage between two phases and current in the measured phase. Then, from those values, parameters like: power factor, effective values of voltage and current, harmonic distortion of voltage and current, are being counted. Calculation of the needed compensation power is done by using the value of allowed reactive power, which is set in the device in the form of requested power factor. According to its size, regulator will switch on or switch off appropriate capacitor stages.

In preference, regulator compensates via semiconductor stages. When it gets to the point when it's not possible any more, the regulator will use contactor stages.

Within the scope of each power level, regulator uses method of circle switching. All the time connects this stage at appropriate power level which was switched off for longest time. Everything is made so that regulator will reach optimal compensation in one regulation cycle with minimum number of switched stages.

The regulator makes harmonics analysis of current and voltage up to 19th harmonics and counts THD factor of

voltage and current.

The regulator can operate not just with compensation capacitor stages, but also with de-compensation reactor stages as well, at the same time. The power of these reactor stages will be registered with the negative numerical sign. De compensation reactors has to be connected after last capacitor stage. If the automatic detection of the powers is not possible, these values could be also set manually. For more details, follow the manual in chapter 6.

5. Installation of the device

Regulator FCR is designed in metal box, which provides perfect EMC shielding. Regulator's design also provides panel mounting, into the hole 138 x 138 mm. The connection of the wires is from the back side of regulator, to the terminals box. Measuring and auxiliary voltages are being taken from supply voltage, which must be protected by fuse 6 A.

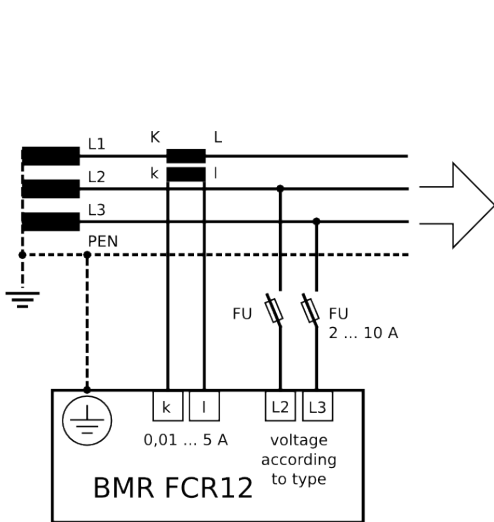

Picture 3: Connection of measuring circuits

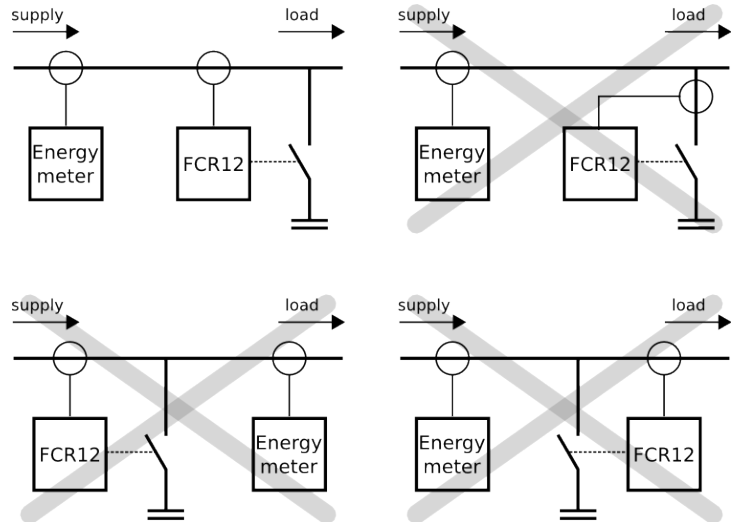

Picture 4: Position of FCR12 controller in the system

Location of the current transformer has to allow both current of the load and the current of the capacitor to be measured together. Correct location is shown on the picture 4 as well as examples of wrong location.

The complete connection is shown at the picture 5. There is only one rule that should be considered. Stages with the same power have to be connected side by side. For example:

1 st stage	2 nd stage	3 rd stage	4 th stage	5 th stage	6 th stage
6,25 kVAr	6,25 kVAr	12,5 kVAr	-	25 kVAr	25 kVAr

However, ranging the powers in accordance is not necessary. There could be even gaps between particular power levels. For example, stages 1 and 2 could be connected, then stage 3 disconnected, stages 4 and 5 connected and so on.

! **Important**
Fast thyristor stages have to be placed from the first stage of regulator outputs. De-compensation reactors is useful to connect behind the capacitors.

Connection diagrams depend on the fact if the regulator controls only contactor stages, combination of contactor and semiconductor stages in one set of six stages, or it controls only semiconductor stages in the set of 6 stages.

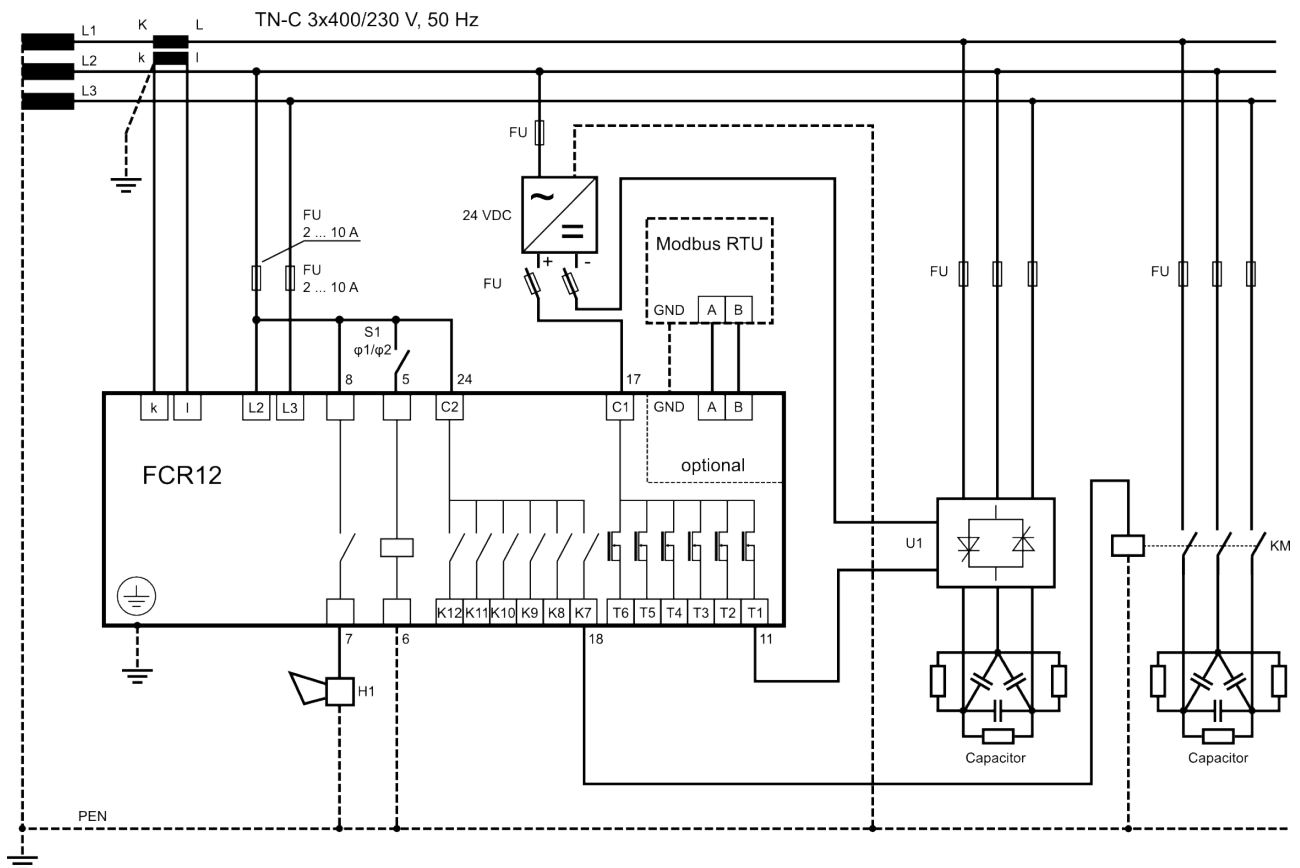

Picture 5a. Connection of the FCR12 controller for contactor and thyristor stages for standard supply voltage 400 VAC

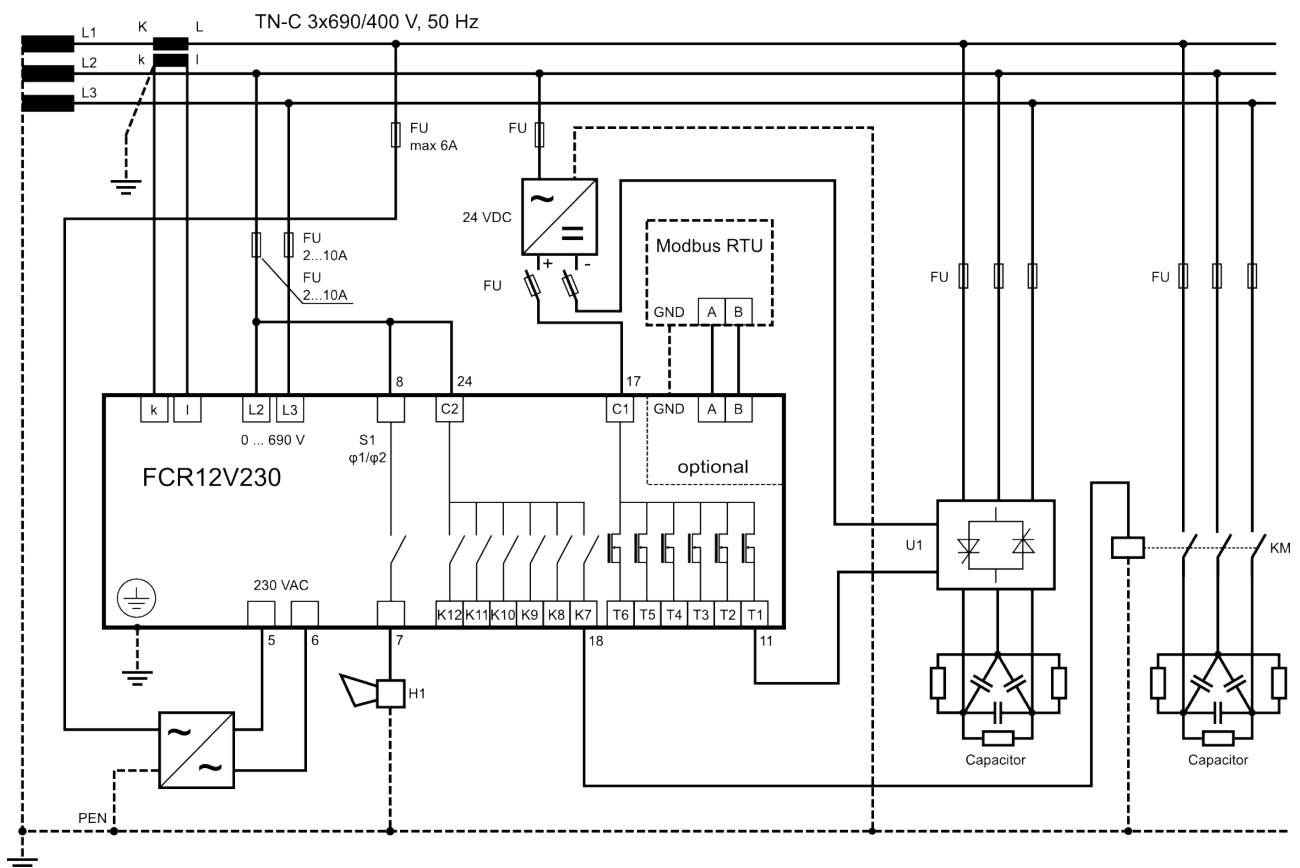

Picture 5b. Connection of the FCR12V230 controller for measuring voltage 0 ... 690 VAC

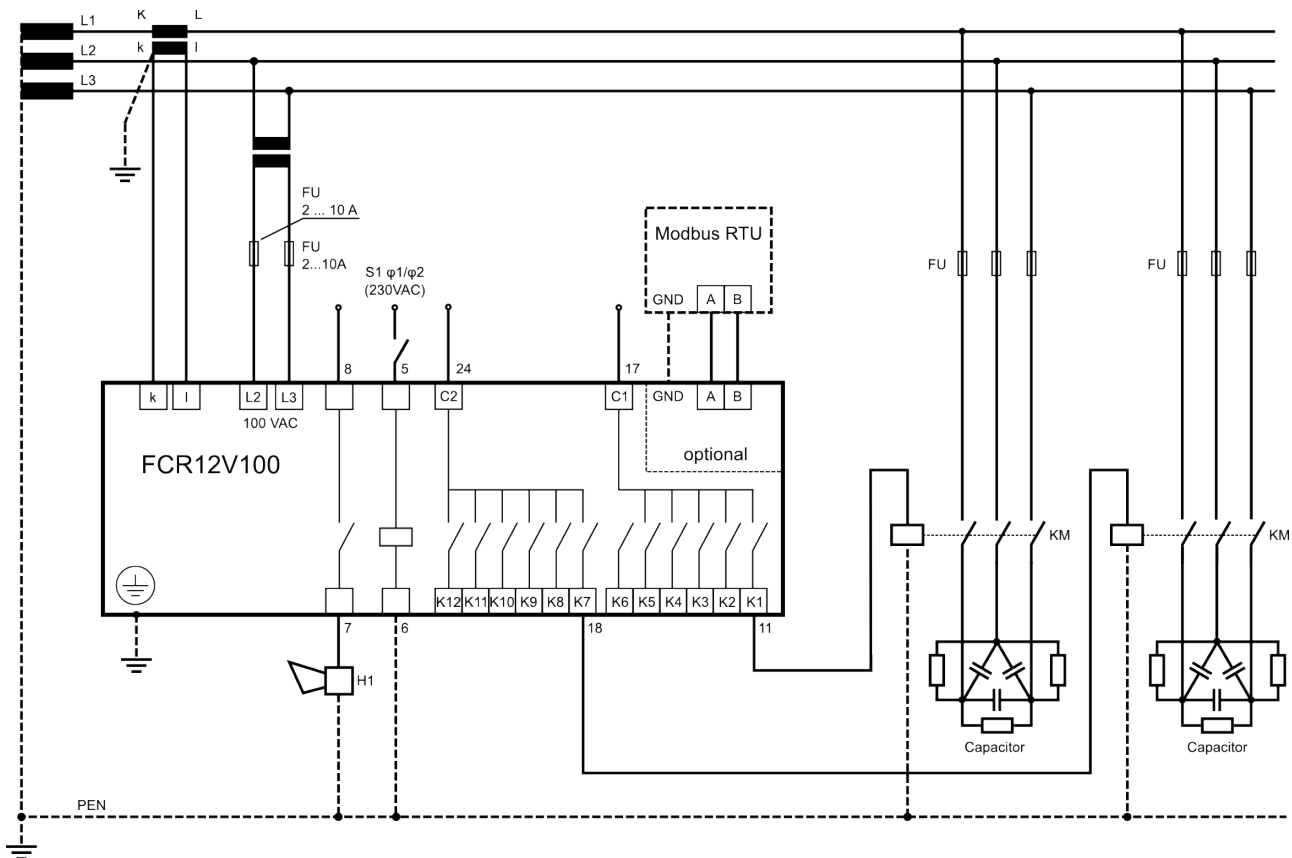

Picture 5c. Connection of the FCR12 controller for supply and measuring voltage 100 VAC

6. Regulator parameter setting

Considering various usage of regulators FCR06 or FCR12, there is a number of programmable parameters. For easy start, regulator is set to default parameters, made by manufacturer. Set parameters are stated in the following table.

For fast start, the parameters that should necessary be set are $\cos\phi$ and transformer ratio of current transformer. Eventually, transformer ratio of voltage transformer could also be set. Further more, there are also other parameters that could be set, in accordance to the customer request.

In order to avoid any unwanted reprogramming of the device, it is possible to protect access to configuration mode by setting the four digits password. By default, new regulator doesn't have any password protection activated. It is recommended to activate password protection after setting all parameters. After the protection has been activated, it is possible to see all set parameters, but not to change any of them.

For checking respective setting set parameters follow those instructions:

1. Press the button **SET** for 5 seconds. Device switches to the configuration mode and parameter **CoS1** will appear on the display. This is a symbol of parameter whose currently set value will appear after another pressing of button **SET**.
2. Via buttons **▲**, **▶** is possible to set the requested value of specified parameter.
3. By pressing the button **SET** again, regulator will save changed value to the internal memory and on display symbol of the set parameter will appear again. Via buttons **▲**, **▶** it is possible to move to another parameter (see the table 4).
4. If the offered parameter is not the one, which is requested to be modified, follow via buttons **▲**, **▶** to the requested parameter.
5. Regulator turns back automatically from configuration mode after 1 minute without any keyboard action, or by repeated pressing of buttons **SET** during returning from parameter value setting.

Important

While configuration mode is activated, device is not regulating. Regulator will not react to the power factor changes, neither

to the changes of other monitored variables. Alarm output will not operate as well.

Parameter	Description	Factory setting	Setting range
CoS1	target cos ϕ	ind 0,98	0,80 cap. ... 0,80 ind. in steps of 0,01
CoS2	target cos ϕ for second tariff	ind 0,90	0,80 cap. ... 0,80 ind. in steps of 0,01
I_tr	current transformer ratio	1	1 ... 6000 in steps of 1
U_tr	voltage transformer ratio	1	1 ... 300 in steps of 1
Auto	automatic detection of compensation stages	oFF	on / oFF
SHtd	deceleration of regulation in the case of over-compensation	60	0 ... 9999 s in steps of 1 s
St_P	manual setting of compensation stages	0	999,9 kVAr cap. ... 999,9 kVAr ind.
dItI	discharging time for thyristor / contactor stage	0/60	5 ... 900 s in steps of 5 s or overdrive of 50 s
dIPA	delay for disconnection of thyristor / contactor stage	0/15	5 ... 900 s in steps of 5 s or overdrive of 50 s
rSSt	number of circuit closing of thyristor / contactor stage	0/99.99	up to 99990
FISt	fixed capacitor stages	Auto	Auto / oFF / on
CoCo	connection configuration	90	0° ... 330° in steps of 30°
rCPo	reactive power offset for regulation	0	0 ... 999,9 kVAr
~CoS	regulation to the average power factor	on	on / oFF / Auto – off regulates on instant. cos ϕ
tACo	averaging time for APFR regulation	60	15, 30, 45, 60 minutes
C_St	saving the step operations and maxim to non volatile memory	oFF	on / oFF
E_IC	activation of inductive steps for de-compensation	oFF	on / oFF
uL.AL	under-voltage alarm	oFF	on / oFF – off alarm does not operate
uL	voltage trigger value for an alarm activation	0	0 ... 750 V
t_uL	minimum event duration for an alarm activation	0	0 ... 3600 s
o_uL	alarm event disconnects compensation steps	oFF	on / oFF
uH.AL	over-voltage alarm	oFF	on / oFF – off alarm does not operate
uH	voltage trigger value for an alarm activation	0	0 ... 750 V
t_uH	minimum event duration for an alarm activation	0	0 ... 3600 s
o_uH	alarm event disconnects compensation steps	oFF	on / oFF
IL.AL	under-current alarm	oFF	on / oFF – off alarm does not operate
IL	current trigger value for an alarm activation	0	0 ... 5 A
t_IL	minimum event duration for an alarm activation	0	0 ... 3600 s
o_IL	alarm event disconnects compensation steps	oFF	on / oFF
IH.AL	over-current alarm	oFF	on / oFF – off alarm does not operate
IH	current trigger value for an alarm activation	0	0 ... 8 A
t_IH	minimum event duration for an alarm activation	0	0 ... 3600 s
o_IH	alarm event disconnects compensation steps	oFF	on / oFF
Co.AL	alarm for cos ϕ , that is permanently over set limits	oFF	on / oFF – off alarm does not operate
_Co	cos ϕ level value for an alarm activation	0	0,80 cap. ... 0,80 ind.
t_Co	minimum event duration for an alarm activation	0	0 ... 3600 s
o_Co	alarm event disconnects compensation steps	oFF	on / oFF
Hu.AL	alarm of voltage harmonic distortion	oFF	on / oFF – off alarm does not operate
tHdu	THDU trigger value for an alarm activation	0	0 ... 50 %
t_Hu	minimum event duration for an alarm activation	0	0 ... 3600 s
o_Hu	alarm event disconnects compensation steps	oFF	on / oFF
HL.AL	alarm of current harmonic distortion	oFF	on / oFF
tHdI	THDI trigger value for an alarm activation	0	0 ... 300 %
t_HI	minimum event duration for an alarm activation	0	0 ... 3600 s
o_HI	alarm event disconnects compensation steps	oFF	on / oFF
ot.AL	alarm for high ambient temperature	oFF	on / oFF – off alarm does not operate

tEPA	temperature level for alarm	55	10 ... 80°C
t_tE	minimum event duration for an alarm activation	0	0 ... 3600 s
o_tE	alarm event disconnects compensation steps	oFF	on / oFF
rS.AL	alarm for exceeding of maximum number of step closing	oFF	on / oFF – off alarm does not operate
tEPV	temperature level for ventilator start	35	10 ... 80°C
Id	device ID number in RS485 network	0	0 ... 255
bAud	communication speed for data transmission	0	0 ... 38400 Bd
PAr	communication control by parity checking	oFF	oFF / on /on_o
CaSC	ID number of parallel controller in cascade connection	0	0 ... 32
CodE	password for access to SET mode	0000	any four digits number 0001 ... 9999
rES	reset to the factory setting	-	

Table 4. Configuration menu parameters

6.1. Target cosF setting (CoS1, CoS2)

Press the button **SET** at least for 5 second for entering configuration mode. On the display will appear parameter symbol **CoS1**. After another pressing of button **SET** display will show set value. Via buttons **▲**, **▶** set new requested value in the limits from 0,8 inductive to 0,8 capacitive. Another pressing of button **SET** saves new value to the memory and on display it will appear again symbol **CoS1**.

For programming **CoS2** follow the same instructions as previous case. For changing from **CoS1** to **CoS2** it is necessary to connect auxiliary supply of 230 V AC to the terminal marked as **2nd Tariff** on the connection diagram.

6.2. Setting of current or voltage transformer ratio (I_tr, U_tr)

If **SET** mode is activated, move by buttons **▲**, **▶** to the parameter **I_tr**. After pressing button **SET**, the set value will appear on the display. Via buttons **▲**, **▶** is possible to change value of transformer ratio. Another press of button **SET** saves new value to the memory and on display, symbol **I_tr** will appear again.

It is important to have in mind that the value which is set, is ratio itself. It means that, for example, if primary nominal current of transformer is 50 A and secondary is 5 A then set parameter value is **I_tr = 10**.

In case of voltage transformer usage, parameter **U_tr** should also be set the same way.



Caution

Measurement range of the current inputs is from 3 mA to 6 A. Maximum of the current transformer ratio is 30000 / 5 A. If the current value is over 5,3 A, alarm will be started, in the case it is enabled.

6.3. Automatic detection of compensation stages (Auto)

Another parameter in the menu is function **Auto**. After pressing of button **SET**, the display will show **oFF**. Via buttons **▲**, **▶** change to the value **on**. After double pressing of button **SET** automatic detection will start to detect connected stages. The symbol **CoCo** will appear on the display, and first capacitor stage will be switched on and off 6 times in the cycle of 20 seconds.

Detection of regulator connection to the network is followed by detection of power of connected capacitor stages. During detection, the measured values of each stage are shown on the display. Measured values are being rounded on 0,5 kvar. After the detection is finished, the regulator will switch parameter **Auto** back to **oFF**.



Important

*In some cases regulator is not able to make automatic detection and in place of measured power shows zeros. It can happen in places with very fast changes of network parameters, where measured values will not be correct. In this case regulator shows **Err1** and it is necessary to set parameters manually, after detailed network measurements.*

6.4. Deceleration of regulation at over compensation (SHtd)

This parameter is represented by symbol **SHtd**. This function is used for slowing down the regulation during over-compensation. At under-compensation regulation is slowed down according to average power factor. This function

assures reduction of switch on/off operation of contactor stages. After pressing the button **SET**, display will show set value of deceleration. By buttons **▲**, **▶** it is possible to change value and button **SET** saves this into the memory. Current situation of regulation deceleration during over-compensation is shown under parameter **Shtd**, in the menu of measured values.

! **Important**

This function does not affect semiconductor stages. Semiconductor stages react immediately.

6.5. Manual setting of compensation stages (St_P)

After parameter **Shtd**, the parameter that follows in the menu is **St_P**. Pressing the button **SET** will enter the sub menu, where it is necessary to select the stage, which has to be set, via buttons **▲**, **▶**. Selected stage will be signalized by green LED. By pressing button **SET** on display will appear set value of stage that is signalized by relevant green LED. Via buttons **▲**, **▶** it is possible to change the value and by pressing button **SET** to save this into memory. Via buttons **▲**, **▶** select another stage, which must be set and follow the same procedure as before. After setting of all stages, keep pressing button **SET** until display will show **St_P** and all LED's will be off.

6.6. Discharging time (dItI)

For setting the absorption of stages, parameter **dItI** is available in the menu. By this parameter, it is possible to set, for each stage separately, suitable time for capacitor discharge. This time can be set from 5 to 900 seconds. Default factory setting value is 60 seconds. Setting procedure is according to the same rules as another parameters explained before.

! **Important**

For semiconductor stages the time is set on 0 seconds, and it is not possible to change it.

6.7. Delay for disconnection (dIPA)

This parameter is represented on the display by symbol **dIPA**. It is the minimum time for contactor stage circuit closing. It is possible to be set from 5 to 900 seconds. Setting procedure is according to the same rules as another parameters explained before.

! **Important**

For semiconductor stages the time is set on 0 seconds, and it is not possible to change it.

6.8. Number of stage circuit closing (rSSt)

On the display, it is represented by symbol **rSSt**. It is possible to set allowed number of circuit closing for each contactor stage. For semiconductor stages, this feature doesn't have any reason. Maximum set value is 99.99, which means 99990 closings. Number that appears on display has to be multiplied by 1000.

6.9. Fixed capacitor stages (FISt)

On the display it is represented by symbol **FISt**. This parameter allows to set stages as a fixed ones. The regulator is not counting those stages for regulation cycle. Each stage can stay in three working regimes.

- **Auto** – stage is normally regulated by controller
- **oFF** – always off (status indication LED blinks red)
- **on** – always on (status indication LED blinks green)
- **tAr2** – stage is always on when second tariff is activated at tariff input

6.10. Connection configuration (CoCo)

If the regulator is connected according the connection diagram on the picture 3 correction angle is 90°. That is default value set by manufacturer. If the regulator is not connected according to this connection diagram, then it is necessary

to make angle correction by displacement of measuring current and voltage. This parameter allows to set angle movement from 0° to 330° in steps of 30°. On the display symbol **CoCo** will be shown. After pressing the button **SET**, the display will show set value. Via buttons **▲**, **▶** it is possible to change the value. Another press of button **SET** will save new value into the memory.

Current transformer location and position		Line voltage					
		L1 (4) - L2 (3)	L2 (4) - L1 (3)	L2 (4) - L3 (3)	L3 (4) - L2 (3)	L3 (4) - L1 (3)	L1 (4) - L3 (3)
L1	k (2) - l (1)	210°	30°	90°	270°	330°	150°
	l (1) - k (2)	30°	210°	270°	90°	150°	330°
L2	k (2) - l (1)	330°	150°	210°	30°	90°	270°
	l (1) - k (2)	150°	330°	30°	210°	270°	90°
L3	k (2) - l (1)	90°	270°	330°	150°	210°	30°
	l (1) - k (2)	270°	90°	150°	330°	30°	210°

Table 5. Phase shift setting for all possible configurations

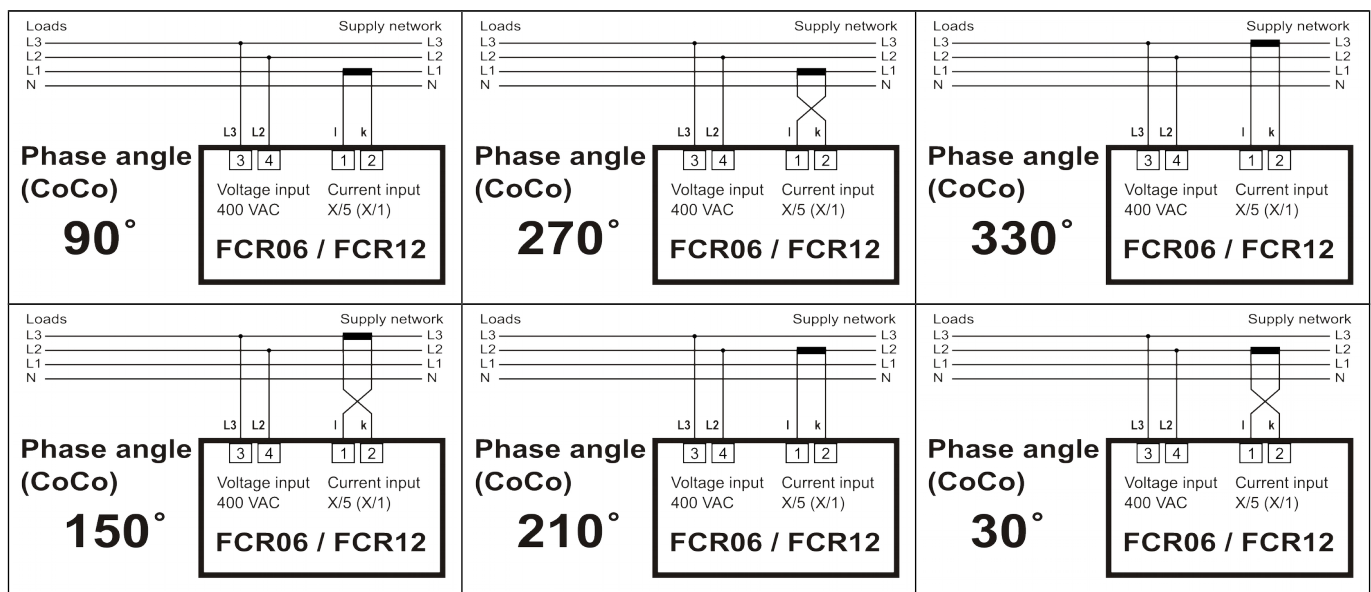

Table 6. Phase shift setting for supply and measuring voltage 400 VAC

6.11. Reactive power offset (rCPo)

This parameter is useful for such type of systems where there is permanent presence of inductive or capacitive reactive power offset. Typical example of this can be long lines which generates permanent and constant capacitive reactive power.

Parameter **rCPo** is set as a real power offset present in the system. This value is then assigned to measured reactive power.

6.12. Regulation to average or instantaneous power factor (CoS)

This setting defines if regulator will regulate slow contactor stages to average or instantaneous power factor. If the set value is **on** then usage of contactor stages is affected by average power factor. If the set value is **off** then regulation is performed only according to instantaneous power factor. In configuration mode move via button **▲**, **▶** to the item **CoS**. After pressing of button **SET** display will show set value **on** / **off** / **Auto**. Via buttons **▲**, **▶** it is possible to change this value. Another pressing of button **SET** saves new value into the regulator memory.



Caution

Option **auto** is a modification for Lithuanian market where there is not defined any area for $\cos\phi$ (for example 0,96 ... 1) but strict limit $\cos\phi = 1$. With enabled option **Auto**, controller is regulating symmetrically according to parameter **SHtd**.

6.13. Averaging time for APFR (tACo)

This setting defines half-period of average $\cos\phi$ calculation. There are available four times for average $\cos\phi$ calculation (15, 30 45 and 60 minutes). Default value of period for average $\cos\phi$ calculation is 30 minutes which refers to half-period set from factory on 15 minutes. It is suitable for most of applications.

After entering selected parameter currently set value of time period will appear. Via buttons ▲, ► it is possible to change this value. Another pressing of button **SET** saves new value into the regulator memory.

6.14. Recording of number of operations and maximum values (C_St)

Activation of this parameters allows the controller to save maximums (the minimum value of frequency is being recorded as well) of measured values into to internal memory.

Monitoring of measured parameters is being done in real time but recording to non volatile memory is done 3 times per 24 hours. Before recording the maximum (minimum) into the memory, this value is kept in standard operating memory. In the case that power supply is lost before recording to non volatile memory the maximum (minimum) values will be lost.

6.15. De-compensation steps settings (E_IC)

For application where there is a need of de-compensation by reactors it is necessary enable inductive steps setting in parameter **E_IC**. If the parameter is set on yes then particular step powers can be set in inductive or capacitive power.

De-compensation by reactor steps is possible be done in two solutions. For application where there is only capacitive load the all steps may be based on de-compensation reactors. For application where there is inductive load which time to time turns to capacitive load the only compensation one step of controller can be based on de-compensation reactor and rest of steps can be based on capacitors. This case the appropriate de-compensation power will be tuned by combination of de-compensation reactor and capacitor steps.

6.16. Alarms

During normal operation alarm output is opened. If there is activated an alarm by an event the alarm output will switch on.

Notice

Alarm output is switched on for 1 minute. After that it is switched off.

Individual events, which activate alarm event can be defined in setting mode by four particular settings. Each alarm event that is requested has to be enabled at first. After that the value of trigger that activated alarm has to be set and also duration of event presence. Last setting option is an alarm event influence on disconnection of compensation outputs.

In the following table there is a list of available alarm events.

Code	Description
UL.AL	Under-voltage alarm
UH.AL	Over-voltage alarm
IL.AL	Low-current alarm
IH.AL	Over-current alarm
Co.AL	Under compensation alarm
Hu.AL	THDU alarm
HI.AL	THDI alarm
ot.AL	Temperature alarm
rS.AL	Alarm from maximum allowed step connection

Temperature alarm is a special alarm which behaves in two levels. If this alarm is activated, alarm output contact is used for ventilator control and cannot be used for any other alarm event indication. Output contact closes when temperature measured by controller goes over level set in parameter **tEPV**. In this case, all alarm events are only shown on the display without output contact action. Second level which disconnects all compensation stages and gives alarm event on display is defined by parameter **tEPA**.

Caution

! If the *ot.AL* alarm is enabled then alarm output is used for ventilator control. All other alarms are then only informative without feedback on the alarm output.

6.17. Configuration of RS485 communication port

Following parameters relate to configuration of serial communication for RS485 port (MODBUS communication protocol).

- **Id** – defines the number of device in the RS485 network and can be set from 1 ... 255
- **bAUd** – defines communication speed between the FCR controller and PC. Default value is 0.
- **PAr** – by default it is set to **oFF** and it can be changed to even (**on**) or odd (**on_o**)

6.18. Parallel work of two controllers (CASC)

Controllers FCR06RS and FCR12RS can work in cascade mode of two controllers. Controllers are connected via RS485 interface which is managing the communication in between. Each controller has to have unique **Id** of serial interface. In parameter **CASC** is then set the Id of opposite controller. For example: there are two controller with Id=1 and Id=2. Then for correct parallel work of both controllers in cascade mode the controller with Id=1 will have set the parameter **CASC=2** and controller with Id=2 will have the parameter **CASC=1**.

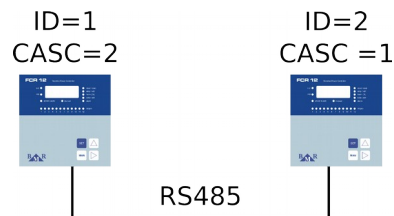

Cascade connection of two controllers

Parallel work of controller cascade does not have defined master and slave. Both controllers can work as a master or slave or even independently. Everything depends on measured conditions of network. In case that one of controllers does not measure any power and if the second controller does not have enough compensation power it offers to second controller its compensation power.

One of the application can be also enlarging the number of outputs in case that there is demand for more than 12 steps. Controller which will be expanding number of outputs only will not have connected the current measuring circuit and will work permanently as a slave.

6.19. Password for entering configuration mode (Code)

Thanks to password is possible to protect regulator against unauthorized configuration. Without proper password knowledge it is possible only see set parameters but not to change them. Password is set as four digit number. In configuration mode move via buttons **▲**, **▶** to the parameter **Code**. After pressing of button **SET** display will show “- - - -”. First dash from left side is blinking. Via button **▲** set number from 0 ... 9 and confirm by button **▶**. Now second dash is blinking and first set number lights on the display. Keep the same procedure until last number is set. By pressing of button **SET**, password for entering configuration mode is saved into the memory. From this moment it is necessary, for each change, type password in order to enter configuration mode. Otherwise any change will not be accepted.

Password protection can be deactivated by the same way as password activating but by entering the code “0000”.

6.20. Restart (rES)

This function restores default configuration. It is last item in the menu and it is represented on the display by symbol **rES**. Press the button **SET** and keep it. At the same time press the button **MAN**. LED of capacitor stages will turn on and then slowly will start to go down. This cycle will repeat two times. After that, the display will show instantaneous value of power factor. Factory setting will be restored.

Important

After restart, it is necessary to set device again as well as make auto detection.

7. Displayed values

Monitoring features do not affect regulation process which is invisibly working all the time. Displayed value is possible to be changed at any time and LEDs on the right side of display identify type of shown value.

Shown values are divided to levels so that values in one level are closely related. For switching between particular levels press button ▲ and for changing screens in one level press button ►. Splitting of shown values to the levels is clear from following list. For returning to the instantaneous **CoSF** press button **SET**.

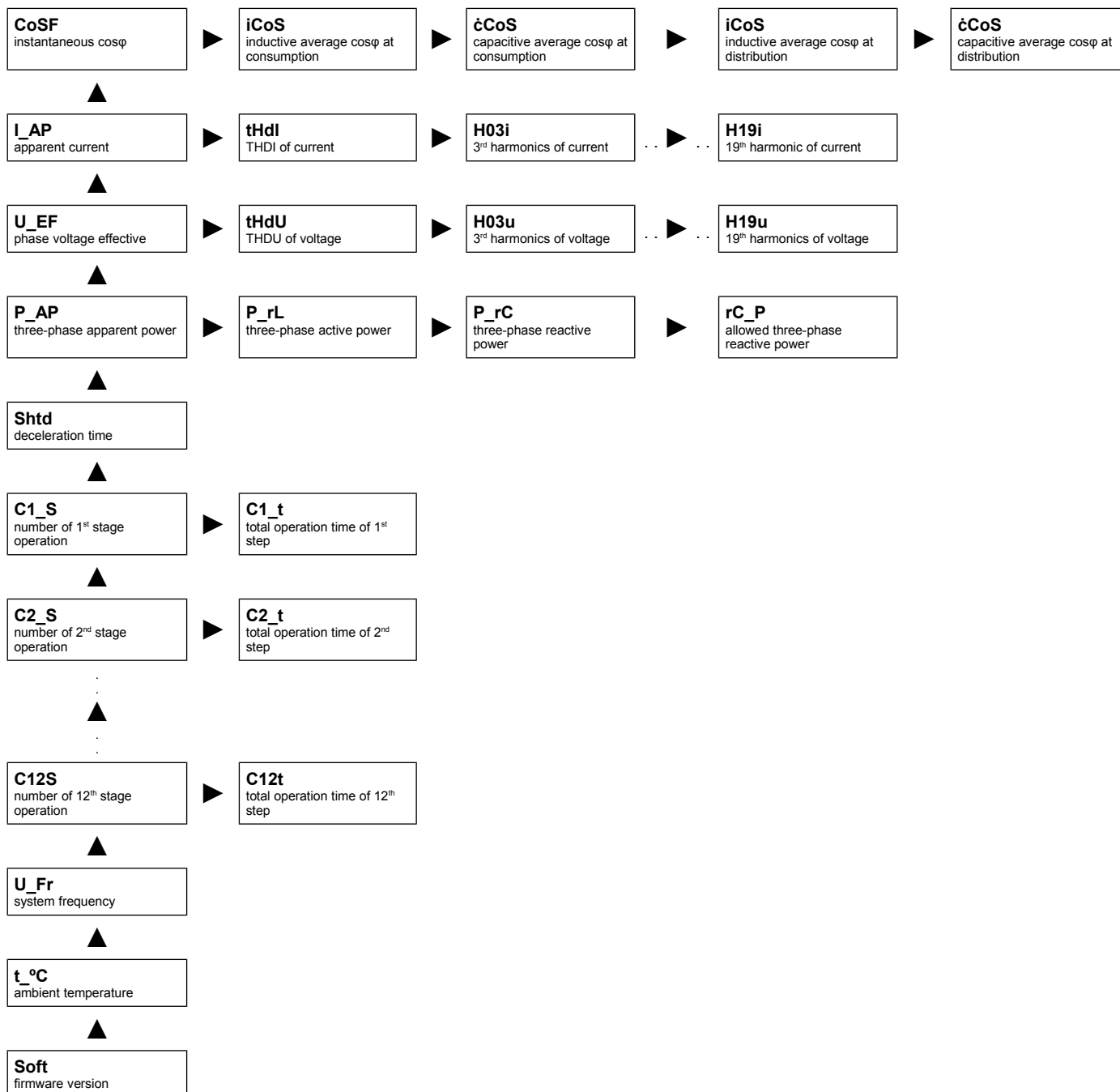

7.1. Maximums

FCR06 and FCR12 controllers record maximums of several measured parameters to volatile memory for information purposes only. Registered maximum values are reset when the power supply is lost.

For getting information about maximum of the measured value, press button **MAN** and the max value will be shown for a while. Keeping the button pressed, the display will show maximum of the measured value.

To erase this maximum value, press together button **MAN** and button **SET**.

7.2. Cosφ

Displaying the cosφ is default indication. This value will appear on display after supply voltage connection and if in current input the current flow is higher than 3 mA. Red LED on the left side of display marked as **ind** and **cap** indicates if measured power factor is in inductive or capacitive area.

If measuring current drops below 3 mA, controller disconnects all stages and on the display will appear " - - - - ". By button **▶** it is possible move to average inductive power factor indication. At first, the display will show symbol **i_CoS** and then after 1 second numeric value will be shown. After pressing the button **▶**, the display will show symbol **ċCoS** and after 1 second it will show numeric value. Another pressing of button **▶** will show **iCOS** during distribution (power supply LED is on), followed by **cCOS** during distribution, and then will return back to instantaneous value of cosφ.

7.3. Apparent current

Pressing of button **▲** will move to another level - apparent current. Symbol **I_AP** will appear on the display for 1 second. After that, the display will show effective value of apparent current on primary side of current transformer, assuming that correct transformer ratio is set in configuration mode, under the parameter **I_tr**.

Another value in this level is current harmonic distortion factor. After pressing the button **▶**, the display will show symbol **tHdl**, which will be replaced after 1 second by actual measured value. For getting information about maximum value or erasing it, follow the same procedure as described above.

7.4. Voltage

This level has exactly the same structure as previous level for apparent current, but this time it is for network voltage.

7.5. Powers

Another level offers values of four powers. At the first position there is apparent power **P_AP**, following by active power **P_rL** and reactive power **P_rC**, respectively and the last but not least there is allowed reactive power **rC_P**. For all powers actual measured value is available and of course also maximum measured value. Procedure of showing or erasing of all values is the same as for previous levels.

7.6. De-compensation delay

This information shows actual remaining time (seconds) to regulation action during over-compensation. Displayed value is decreased each second by square of true control deviation and requested power factor value.

7.7. Number of stage circuit closings

Number of stage circuit closings is divided to the 6 for FCR06 (12 for FCR12) independent levels. For the first stage, the display will show symbol **C1_S** and after it disappears the number of first stage circuit closings will be displayed. By simultaneous pressing of buttons **SET** and **MAN** this information can be erased. To another level, where information about second stage is, move by pressing the button **▲**. The rest of procedure is the same as for the first stage.



Note

For semiconductor stages number of circuit closings is not recorded.

7.8. System frequency

Next to the last level is system frequency **U_Fr**. Also at this level, actual value of system voltage frequency, maximum value and minimum value are available. Showing of actual and maximum values is the same as for previous levels.

7.9. Temperature

Last level shows regulator ambient temperature **t_°C**. Both actual and maximum value are possible to be seen.

Showing or erasing these values is the same as for previous levels.

8. Manual operation

Switching the regulator to the configuration mode and by subsequent press of button **MAN**, manual regulation of compensation stages will be activated. The status is indicated by LED with label **manual**. On the display, symbol **St_1** will be shown for 1 second. After that, it will be replaced by actual value, which blinking (manual mode indication). Button **▲** allows to change stage status with respecting the set discharging time and delay for stage disconnection. It means that if the stage was disconnected, pressing the button **▲** will switch the stage on. If the stage was connected, the same button will switch the stage off. For another stage selection press button **▶**. After pressing this button, the display will show for 1 second symbol **St_2**, representing another stage. The whole procedure is the same like for the previous stage. By pressing the button **MAN**, manual mode can be deactivated.

9. Alarm notification

If at least one of enabled alarm events appeared, then alarm output relay will be switched on for 1 min and LED with label **alarm** will blink on the display. This LED will also blink after the alarm event disappears, until it gets cancelled by long press of button **SET**. Alarm notification does not have any influence to regulator behaviour, except in the case when alarm is activated by high harmonic disturbance.

The symbol of alarm sort is shown on the display after pressing of button **SET** for at least 5 seconds. Symbol of the event that caused the alarm will appear on the display. Another pressing the button **SET** will cancel shown alarm. If more alarm events happened, another event symbol will appear on the display. By keeping the same procedure, it is possible to follow till last alarm event is cancelled. In the displayed values mode it is possible to find out which values of alarm events activated alarm (chapter 7). Alarm event symbols are the same as symbols used during alarm setting in configuration mode.

10. Technical features

Parameter	Value
Supply voltage / measuring voltage	400 V AC 50 Hz (+10%,-15%)
Frequency	50 / 60 Hz
Current range	0,003 ... 6 A
Measurement accuracy of current input	±1%
Power consumption	10 VA
Output channels number	6 or 12
Switching power of alarm output	250 VAC / 5 A
Switching power of relay contacts	250 VAC / 5 A
Switching power of semiconductor contacts	24 VDC / 100 mA or 230 VAC / 100 mA
Switching speed of semiconductor stages	25 operations per second
Range of requested power factor	0,8 ind. ... 0,8 cap.
Re-connection delay: semiconductor / contactor stages	0 s / 5 ... 900 s
Switching off delay: semiconductor / contactor stages	0 s / 5 ... 900 s
Compensation stages value setting	manually / automatically
Communication port	RS485 (optional)
Communication protocol	MODBUS RTU
Communication speed	9600 ... 38400 Bd
Temperature limit	-40°C ... +70°C
Front panel	144 mm x 144 mm
Panel cutout	138 mm x 138 mm
Site depth	55 mm
Weight	1 kg (including packaging)
Protection degree	IP20 rear cover / IP54 front panel
Standards	EN 61010-1, EN50081-1, EN50082-1