

Thyristor Switching Modules

The thyristor switching modules of CTU range were developed for usage in applications with fast load changes (welding plants, stamping plants, lifts, cranes, controlled drives, etc.). With such types of loads, the standard mechanical contactor operated PFC is not able to compensate the reactive power at the targeted power factor level.

Thyristor switching modules CTU01 and CTU02 are designed for switching capacitor steps in fast dynamic PFC application. The construction determines their usage in 3-phase systems with needs of fast reaction to the load changes.

CTU03 thyristor switching modules have been developed for the switching of 1-phase capacitors connected into a Δ or Y connection. Variants of the CTU33 thyristor switching modules offer independent control of 1-phase capacitors connected between phases to compensate reactive power and also to balance a 3-phase network.

Operation principle

Thyristor switching modules are constructed for the switching of L-C circuits with prevailing capacitive part (detuned compensation stages).

The advantage of thyristor modules of the CTU range compared to the classic mechanical contactor switching of capacitor steps is an immediate connection of the capacitor without its previous discharging. This is possible thanks to special construction which assures that the capacitor is ready for another connection immediately after its previous disconnection. The switching of the capacitor is achieved at the moment when the difference between the capacitor voltage and system voltage is equal to zero.

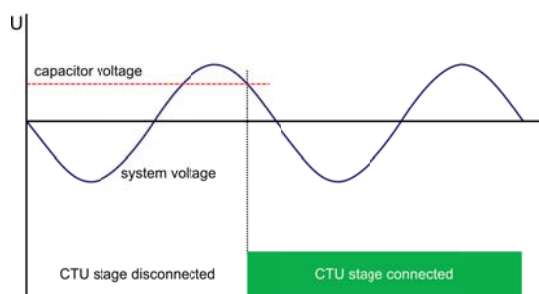

From this feature comes another important advantage and this is significant current surges reduction. Current surges cause disturbances which can affect proper running of electronic devices and can severely damage and even destroy them. Further more, the lifetime of capacitors is increased because only nominal current flows through the circuit. For the protection of the power switching element against current peaks (di/dt), it is necessary to connect the JTC inductor to the module.

Ranges of thyristor switching modules

Type	Switcher in L1, L2, L3	Switcher in L1 and L3	Max 3-ph. C power [kVAr]	Max 1-phase C power [kVAr]	Control voltage 230 V _{AC}	Control voltage 24 V _{DC}	Rated grid voltage 400 V _{AC} 50 Hz (+10%, -15%)*	Rated phase current [A]	Forced ventilation	Dimensions [mm]	Weight [kg]	
Thyristor switching modules for 3-phase capacitors	CTU 01-400-15	•	15		○	•	•	22		200 x 120 x 155	3.4	
	CTU 01-400-30	•	30		○	•	•	43		200 x 120 x 225	5.0	
	CTU 01-400-50	•	50		○	•	•	72	•	238 x 120 x 225	5.6	
	CTU 01-400-72	•	72		○	•	•	104	•	238 x 120 x 225	5.9	
	CTU 02-400-15	•		15		○	•	•	22		200 x 120 x 155	3.5
	CTU 02-400-30	•		30		○	•	•	43		200 x 120 x 225	5.1
	CTU 02-400-50	•		50		○	•	•	72	•	238 x 120 x 225	5.7
	CTU 02-400-72	•		72		○	•	•	104	•	238 x 120 x 225	6.0
Thyristor switching modules for 1-phase capacitors	CTU 03-400-10	•		3 x 6		○	•	•	15		200 x 120 x 155	3.5
	CTU 03-400-30	•		3 x 17		○	•	•	43		200 x 120 x 225	5.1
	CTU 03-400-50	•		3 x 30		○	•	•	72	•	238 x 120 x 225	5.7
	CTU 03-400-72	•		3 x 42		○	•	•	104	•	238 x 120 x 225	6.0

• – Default feature ○ – Optional feature * – Other voltages on the request

Switching modules for 3-phase capacitors

Thyristor switching modules for three-phase capacitors are made for fast speed compensation and also for smooth disturbance less operation. Modules are designed for easy construction of a PFC cabinet that follows the same rules as PFC cabinets based on standard mechanical contactors and three-phase capacitors protected by detuned reactors.

Control voltage variants

For easier assembling of the cabinet, two control voltages are offered. The standard and recommended 24 V_{DC} or an optional 230 V_{AC} preferred for hybrid power factor cabinets.

Over-temperature protection

Inside each CTU module there is a temperature sensor. If the temperature of this sensor exceeds 80°C then the control board disconnects all semiconductor switchers to protect the module against damage. For modules equipped with a ventilator, the sensor is also used for forced ventilation control.



CTU02 module with switcher in L1, L2, L3

The thyristor switching module CTU02 with maximum switching speed performance of 3-phase capacitors. Special construction solves voltage discharging time limitation so the three-phase capacitor can be switched again immediately after disconnection without prior discharging. Switching is completed within 10 ms of receiving the signal from the PF controller. Thanks to the construction, the effective operation speed can be up to 25 operations per 1 second.

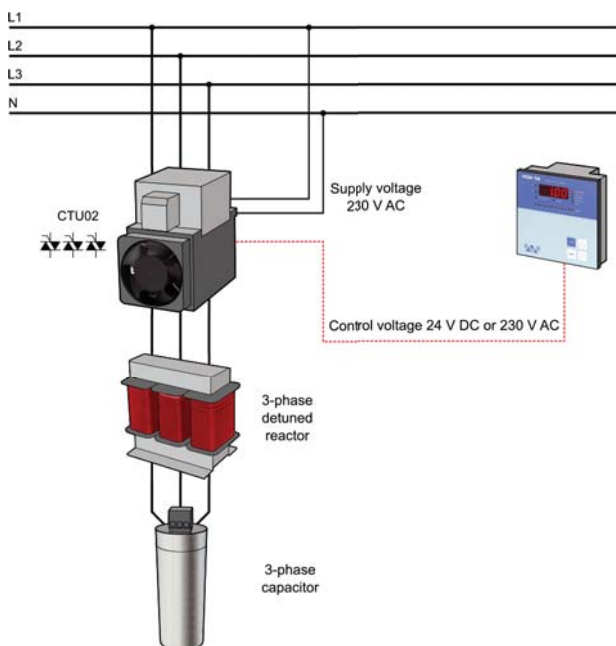

CTU01 module with switcher in L1 and L3

The thyristor switching module CTU01 is designed for smooth contactless switching of 3-phase capacitors. The connection of is completed within 10 ms of receiving the signal from the power factor controller. The maximum speed of reconnection is about 1 operation in 5 seconds, depending on the discharging resistors.

The typical application for usage of CTU01 modules are loads with periodical power changes every 10 – 30 seconds.

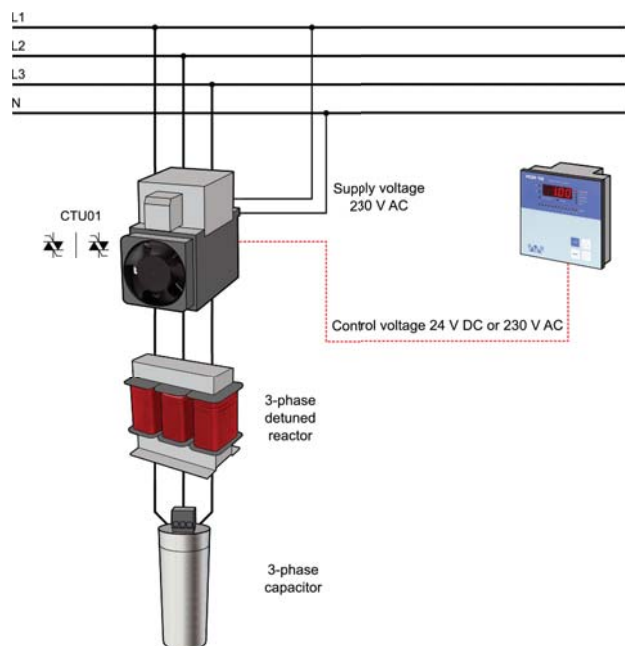

Technical features

System voltage	400 V _{AC} (+10%, -15%) - Δ connection
System frequency	50 Hz / 60 Hz
Auxiliary supply voltage	230 V _{AC} 50 Hz / 2 VA
Control voltage	24 V _{DC} or 230 V _{AC} 50 Hz
Power consumption of control input	0.24 VA
Reverse blocking voltage	1600 V
Temperature protection	internal +80°C
Type of switched load	R, C, LRC

Power dissipation	max. 60 / 150 / 250 / 300 W
Fan power consumption	3 VA
Working temperature	-25°C + +45°C
Conductor size	35 mm ²
Supply voltage indication	green LED
Operating status indication	red LED in each phase
Mounting position	vertical and horizontal
IP rating	IP00

Switching modules for 1-phase capacitors

CTU03 / CTU33 modules for 1-phase capacitors

The range of thyristor switching modules CTU03 is designed for the switching of 1-phase capacitors connected to a Δ or Y connection. An advantage of CTU03 modules is the higher capacitive power that it can operate at. The maximum power is 126 kVAR per CTU03-400-72 module.

The variant CTU33 is equipped with 3 independent control inputs for operation by the controller FCR123.

Switching is completed within 10 ms from receiving the signal from power factor controller. This feature assures a switching speed up to 25 operations per 1 second.

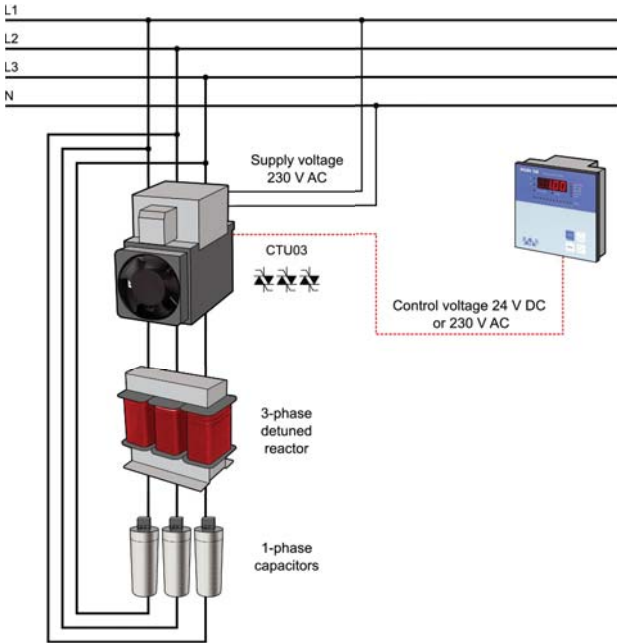

Optical signalization

Each phase has an LED signalization of its operating state to easily identify if the phase is connected or disconnected.

Over-temperature protection

Inside each CTU module there is a temperature sensor. If the temperature of this sensor exceeds 80°C, then the control board disconnects all semiconductor switchers to protect the module against damage. For modules equipped with a ventilator, the sensor is also used for forced ventilation control.

Technical features

System voltage	400 V _{AC} (+10%, -15%) - Δ connection 690 V _{AC} (+10%, -15%) - Y connection
System frequency	50 Hz / 60 Hz
Auxiliary supply voltage	230 V _{AC} 50 Hz / 2 VA
Control voltage	24 V _{DC} or 230 V _{AC} 50 Hz
Power consumption of control input	0.24 VA
Reverse blocking voltage	1600 V
Temperature protection	internal +80°C
Type of switched load	R, C, RLC

Power dissipation	max. 60 / 150 / 250 / 300 W
Fan power consumption	3 VA
Working ambient temperature	-25°C + 45°C
Conductor size	35 mm ²
Supply voltage indication	green LED
Operating status indication	red LED for each phase
Mounting position	vertical and horizontal
IP rating	IP00
Supported controllers	FCR06/12, GCR06/12, FCR123

Variants codes of thyristor switching modules

Instrument name	CTU 02 - 400 - 50 - V230
type of module	
01	switching element in L1 and L3
02	switching element in L1, L2, L3
03	module for 1-phase capacitors
33	module for FCR123 controller
Nominal network voltage	
400	400 VAC nominal voltage
Nominal three-phase capacitor power	
Control voltage	
-	24 VDC control voltage
V230	230 VAC control voltage